

2/2 WAY FINNED BONNET (WCBF) CONTROL VALVES WITH ELECTRIC ACTUATOR.

BILL OF MATERIAL

Item	Parts	Material
1	Body	SS ASTM A351CF8/CF8M
		CS ASTM A216, Gr. WCB, SGI.
2	Seat	SS AISI 420/ SS AISI 316
3	Gasket	Cr.Ni Foil coated with graphite.
4	Plug	SS AISI 420/ SS AISI 316
5	Duro Bush	PTFE Lined & coated, SS backed.
6	Bonnet	SS ASTM A351CF8/CF8M
		CS ASTM A 216, Gr. WCB
		SGI
7	Studs/ Nuts	IS 1363, ASTM A193, Gr.B7
		IS 1363, ASTM A 194, Gr.2H
8	Gland Packing	Graphited PTFE
9	Gland Nut	SS AISI 304
10	Yoke Nut	CS ASTM A216, Gr. WCB
11	Actuator	Electric Actuator

◆ Refer to actuator leaflet for details of components.

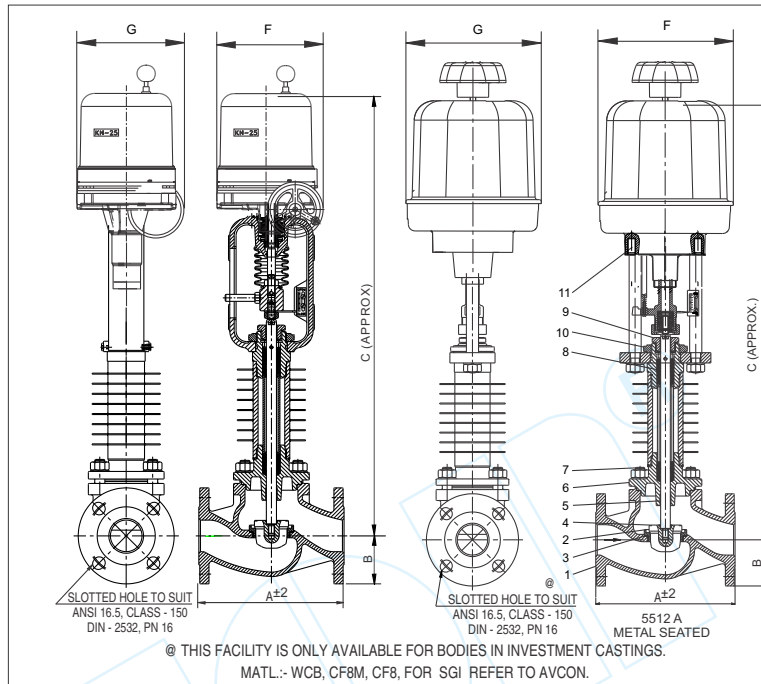

TECHNICAL DATA TABLE

Valve size in mm	15	20	25	40	50	65	80	100	150
Port Sizes 2-way	18	22	25	40	50	65	80	100	150
Kv. M ³ /hr.	4	6.3	10	25	40	63	100	160	400
Travel	20	20	20	20	30	30	30	30	30
	30	30	30	30					50
Electric Actuator	KN 05	KN 05	KN 05	KN 05	KN 05	KN 07	KN 07	KN 10	KN 10
					KN 07	KN 10	KN 10	KN 25	KN 25

DIMENSIONS (IN MM)

Catalogue Number	Size	Electric Actuator	A	B	C	F x G or ØD	Wt. Kg. (Approx.)	Envelope Size LxHxW (Approx.)	Box Wt. Kg. (Approx.)
	Inch								
5512A155/WCBF x KN 05	1/2	KN 05	130	44.5	553	Ø178	9.0	648 x 240 x 167	11.0*
5512A205/WCBF x KN 05	3/4	KN 05	150	49	553	Ø178	10.0	652 x 240 x 167	12.0*
5512A255/WCBF x KN 05	1	KN 05	160	54	608	Ø178	12.5	712 x 240 x 167	13.0*
5512A405/WCBF x KN 05	1 1/2	KN 05	200	63.5	621	Ø178	17.0	735 x 240 x 167	22.0*
5512A505/WCBF x KN 05	2	KN 05	230	76	730	Ø178	23.0	856 x 203 x 203	31.7*
5512A501/WCBF x KN 07		KN 07			835	Ø225	32.0	961 x 250 x 250	41.0*
5512A655/WCBF x KN 07	2 1/2	KN 07	290	89	835	Ø178	34.0	894 x 203 x 203	44.0**
5512A805/WCBF x KN 07	3	KN 07	310	95.5	755	Ø225	40.0	994 x 250 x 250	51.0**
5512A801/WCBF x KN 10		KN 10			855	Ø225	55.0	1070 x 250 x 250	66.0**
5512A1005/WCBF x KN 10		KN 10			930	Ø225	77.0	1095 x 250 x 250	87.0**
5512A1001/WCBF x KN 25	4	KN 25	350	114.5	1012	Ø260	81.0	1177 x 285 x 285	86.0**
5512A1505/WCBF x KN 10	6	KN 10	480	139.5	988	Ø225	93.0	1178 x 250 x 250	93.0**
5512A1501/WCBF x KN 25		KN 25			1070	Ø260	97.0	1260 x 285 x 285	109.0**

Note: * Weight of cardboard + PUF Box Packing. Which may change for Export when packed in wooden box. ** Weight of Wooden Box Packing.

Note:

Technical specifications, details & dimensions are subject to change without prior notice. Dimensions in the table are approximate subject to final confirmation by AVCON.