

2/2 WAY RUBBER LINED DIAPHRAGM SEATED VALVES WITH PNEUMATIC MULTI SPRING ACTUATOR.(NC)

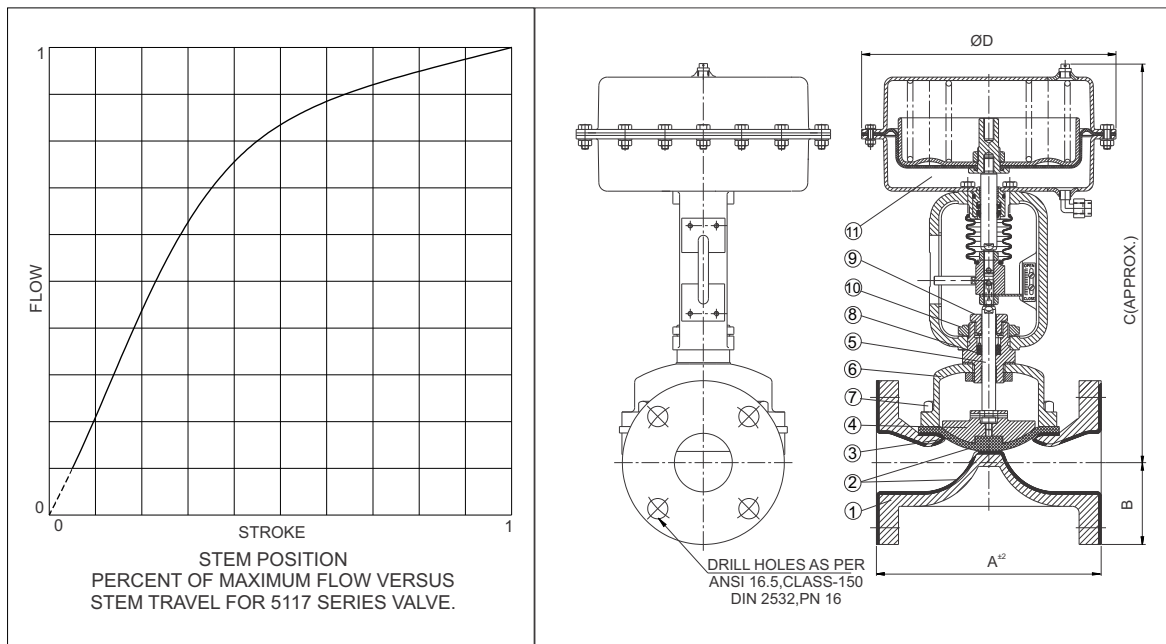

BILL OF MATERIAL

Item	Parts	Material	Item	Parts	Material
1	Body	CS ASTM A216, Gr. WCB CI	7	Studs/Nuts	IS 1363, ASTM A 193, Gr.B7
2	Body Lining	NEOPRINE, / HYPLON, with lining H.R. NITRILE	8	Gland Packing	Graphited PTFE
3	Diaphragm	NEOPRINE, BUNA NITRILE, HYPLON, SILICON, EPDM.	9	Gland Nut	SS AISI 304
4	Compressor	CI	10	Yoke Nut	CS ASTM A216, Gr. WCB
5	Stem	SS AISI 410	11	Actuator	Multi Spring \diamond Pneumatic Diaphragm
6	Bonnet	CI	\diamond Refer to actuator leaflet for details of components.		

VALVES IN THIS SERIES ARE HAVING FLANGES IN FLAT FACE ONLY. DIMENSIONS (IN MM)

Catalogue Number	Size	Pneumatic Actuator	A	B	C	ØD	Wt Kg. (Approx.)	Envelope Size LxHxW (Approx.)	Box Wt. Kg. (Approx.)
	Inch								
5117B255 x 400	1	400	160	54.0	401	300	13.5	505 x 325 x 325	18.5*
5117B305 x 400	1 1/4	400	180	58.5	408	300	15.0	517 x 325 x 325	20.0*
5117B405 x 400	1 1/2	400	200	63.5	414	300	16.5	528 x 325 x 325	23.5*
5117B405 x 800	1 1/2	800	200	63.5	456	405	23.0	570 x 430 x 430	30.0*
5117B505 x 400 5117B505 x 800	2	400/800	230	76.0	465	300/405	27.5	591 x 325 x 325 591 x 430 x 430	37.5* 42.5*
5117B655 x 800	2 1/2	800	290	89.0	485	405	33.0	624 x 430 x 430	48.0**
5117B805 x 800	3	800	310	95.5	665	405	80.0	811 x 430 x 430	100.0**

Note:

* Weight of cardboard + PUF Box Packing. Which may change for Export when packed in wooden box.

** Weight of Wooden Box Packing.

For Normally Open Valve details please contact avcon.

Note:

Technical specifications, details & dimensions are subject to change without prior notice.

Dimensions in the table are approximate subject to final confirmation by AVCON.